

N 90
T59TS61N0
FLEXINDUCTION COOKTOP WITH TWISTPAD® FIRE
CONTROL

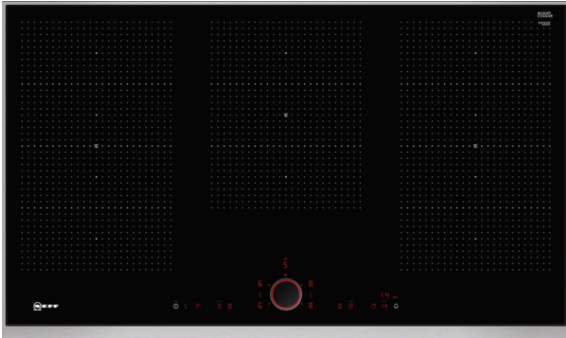

Standalone FlexInduction cooktop with TwistPad® Fire control.

- ✓ Induction - With induction cooking, the heat is generated directly in the cookware for precise cooking that stops when power is off.
- ✓ FlexInduction - The FlexZone lets you place your pots and pans anywhere you want and heats them exactly where they stand.
- ✓ The TwistPad® Fire is a removable, magnetic, illuminated control knob that gives you precise, convenient control over all cooking zones. And to make things even easier, only the selectable functions are illuminated.
- ✓ PowerMove - The FlexZone is divided into three heating zones: boiling in front, simmering in the middle and warming in the rear.
- ✓ FryingSensor - The FryingSensor with 5 selectable temperature settings monitors the set temperature and holds it steady. So there's no more burning.
- ✓ Stainless-steel flush-fitted trim

Features

Technical Data

Product name/family : Cooking zone ceramic
 Construction type : Built-in
 Energy input : Electric
 Total number of positions that can be used at the same time : 5
 Required niche size for installation (HxWxD) : 51 x 880-880 x 490-500
 Width of the product (mm) : 918
 Dimensions of the product (mm) : 51 x 918 x 546
 Dimensions of the packed product (HxWxD) (mm) : 126 x 1073 x 603
 Net weight (kg) : 21.3
 Gross weight (kg) : 23.0
 Residual heat indicator : Separate
 Location of control panel : Hob front
 Basic surface material : Ceramic
 Color of surface : Black, Stainless steel
 Color of frame : Stainless steel
 Approval certificates : AENOR, CE
 Length electrical supply cord (cm) : 110
 EAN code : 4242004189374
 Electrical connection rating (W) : 11100
 Voltage (V) : 220-240
 Frequency (Hz) : 60; 50

Optional accessories

Z9410X1	Stainless Steel roaster with glas lid
Z9415X1	Steaming Rack for Stainless Steel roaste
Z9416X2	Griddle Plate
Z9417X2	Teppan Yaki (large)
Z9442X0	Set of 3 pots and 1 pan
Z9453X0	System pan diameter 21cm



N 90

T59TS61N0

FLEXINDUCTION COOKTOP WITH TWISTPAD®

FIRE CONTROL

Features

Handling

- TwistPad® Fire

Flexibility

- 3 Flex zones
- 5 induction zones
- Cooking zones:
 - 1 x Ø 400 mmx240 mm, 3.3 KW (max. Power level 3.7 KW)
Induction or 2 x Ø 240 mm, 2.2 KW (max. Power level 3.7 KW)
Induction;
 - 1 x Ø 300 mmx240 mm, 2.6 KW (max. Power level 3.7 KW)
Induction;
 - 1 x Ø 400 mmx240 mm, 3.3 KW (max. Power level 3.7 KW)
Induction or 2 x Ø 240 mm, 2.2 KW (max. Power level 3.7 KW)
Induction

Comfort & Convenience

- PotBoost function for all cooking zones
- PanBoost
- PowerMove
- FryingSensor with 5 temperature settings
- 17 power levels for each cooking zone
- Residual heat indicator: Digital 2-step
- LED display and timer with auto switch off for all cooking zones,
Count up timer, Alarm clock
- Automatic pan recognition sensor
 - Power management function
 - Automatic safety switch-off
 - Child safety lock
 - Wipe protection function
- ReStart function
- QuickStart - Quick and automatic first pot detection
- Keep warm function for all cooking zones
- Energy consumption display

Design

- Black ceramic glass with stainless steel flush-fitted trim

Technical Information

- 90 cm width
- Installation measurements: 880 mm x 490 mm
- Length wire connection: 110 cm
- Min. worktop thickness: 30 mm
- 11.1 kW total connected load
- Voltage: 220 - 240 V
- Cable included

N 90
 T59TS61N0
 FLEXINDUCTION COOKTOP WITH TWISTPAD®
 FIRE CONTROL

Dimensioned drawings

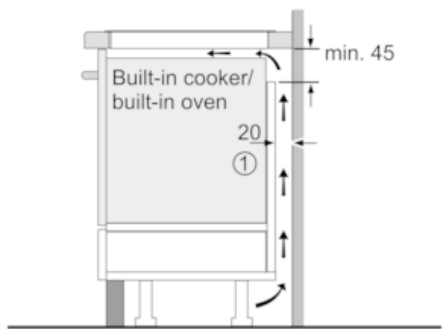

① Ventilation gap must be present

All measurements in mm

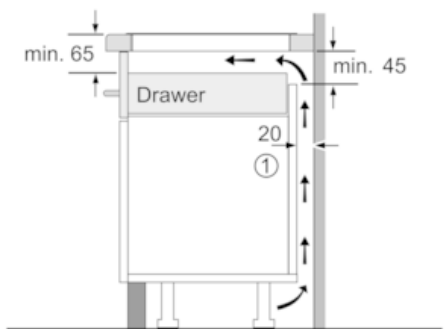

① Ventilation gap must be present.

Measurements in mm

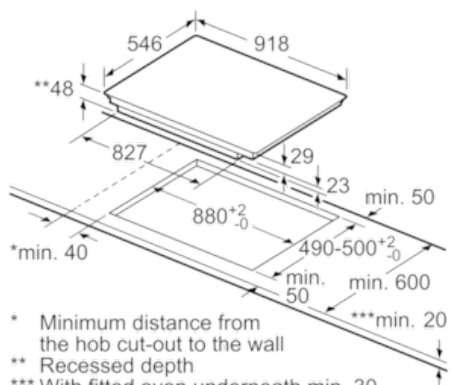

* Minimum distance from the hob cut-out to the wall
 ** Recessed depth
 *** With fitted oven underneath min. 30, possibly more; see space requirements for the oven

measurements in mm